

# PRODUCTS



# HISTORY

## 1957

Founded in Forest Park, IL (suburb of Chicago) by a former engineer of a large auto parts manufacturer. This individual built custom cranes on a one-off basis and saw a need for these cranes in neighboring Midwest factories.

## 1964

As the crane business grew, the company decided to move to a more adequate facility in La Grange, IL.

## 1975

Custom cranes were the foundation, but dealers drove Handling Systems to develop a more standard product line to better enable its growing dealer only based sales force to sell the products to factories across the country.

## 1995

Mark Rehor and partners purchased the business. They officially changed the name to Handling Systems International, Inc.

## 2000

Further developments were made to grow the dealer-based network through outlets like the online catalogs and various other catalog houses.

## 2012

Mark Rehor purchased 100% of the business, alongside his sons Mike and Mark (Jake) Rehor. A complete revitalization is started with a heavy focus on sales, product development, and manufacturing efficiency.

## 2013

The New H.S.I. logo was introduced along with a new domain ([www.hsicrane.com](http://www.hsicrane.com)).

## 2019

After perpetual growth over the past seven years of revitalization, Handling Systems moves into its new home; a 60,000 SF facility in McCook, IL.

Handling Systems announces exclusive partnership with Niko (Helm Hellas SA) to enable the company to have a complete line of enclosed track crane systems offered to dealers. All NikoRail enclosed track crane systems are manufactured in McCook, IL USA.

## 2020

Handling Systems launches new dealer crane sales training center.

# CONTENTS

## Jib Cranes

Tie Rod Style Jib Crane	4
Cantilever Style Jib Crane	5
Mast Type Jib Crane	6
Light Duty Freestanding Jib Crane	7
Portable Jib Crane	8
Articulating Jib Crane	9
Heavy duty Freestanding Jib Crane	10
Motorized Jib Cranes	11
Enclosed Track Workstation Jib Cranes	12
Foundationless Jib Cranes	13

## Gantry Cranes

Fixed Height Steel Gantry Crane	14
Adjustable Height Steel Gantry Crane	15
Adjustable Height Aluminum Gantry Crane	16
Motorized Gantry Crane	17

## Bridge Cranes, Runways and Monorails

Bridge Cranes and Runways	18
Monorails	19

## Design Standards and Warranty

Design Standards	20
Warranty	21

# Tie Rod Style Jib Crane

12+ Ton | 35+ Ft Span | Manual or Motorized

The model 311 tie rod style wall bracket jib crane is an economical jib crane solution designed for individual use in bays, along walls, in work cells, or as a supplement to overhead crane or gantry systems.

## Maneuverability

This design allows for a lighter beam weight, and when combined with bronze bushings and oil impregnated bronze thrust washers, it becomes the perfect solution for easy rotation and precise load positioning.

## Capacities & Spans

- Capacities up to 12 ton
- Standard Span lengths up to 35 feet

## Rotation

205+ degree rotation is standard

## Benefits Vs. Cantilever Style

- More economical solution
- Less beam deflection
- Smaller beam sizes
- Easier to rotate even when used at higher capacities
- Greater hook travel to move load closer to mounting point
- Easy to adjust during and after installation

## Standards

### Fabrication

All designs meet AISC standards as they pertain to jibs and overhead cranes. All model 311 jib cranes are in accordance with OSHA specification 1910.179. Model 311 jib cranes are built to CMAA specification No. 74. All design and manufacturing is done in accordance to ANSI specification B30.11 as they apply to jib cranes and overhead cranes.

### Material Standards

All steel I beams used by Handling Systems are a minimum of ASTM A-36 designation.

### Deflection Criteria

Standard design is based on  $L(\text{span in inches})/600$  at midspan. The value of this formula is theoretical and will be increased during field load tests due to possible variables.



## Easy to Install

- Single tie rod, right hand threaded at both ends
- Bolted connections with bolt on trolley end stops
- Grease fittings included for easy field lubrication

## Special Applications

- Motorized Rotation Available
- Spark and Explosion Proof Options Available
- Stainless Steel & Foodgrade Options Available

## Options & Accessories

- Tight Wire Kit (Festooning/Tagline)
- Rotation Stops
- Motorized Rotations
- Outdoor Applications
- Hoist & Trolley Packages

## D.I.Y. Fitting Kits Available

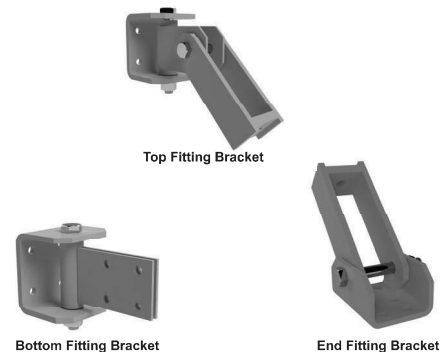

# Cantilever Style Jib Crane

12+ Ton | 35+ Ft Span | Manual or Motorized

The model 313 cantilever style column mounted jib crane is a low headroom style crane designed for individual use in bays, along walls, in work cells, or as a supplement to overhead crane or gantry systems.



## Easy to Install

- Single tie rod, right hand threaded at both ends
- Bolted connections with bolt on trolley end stops
- Grease fittings included for easy field lubrication

## Special Applications

- Motorized Rotation Available
- Spark and Explosion Proof Options Available
- Stainless Steel & Foodgrade Options Available

## Options & Accessories

- Tight Wire Kit (Festooning/Tagline)
- Rotation Stops
- Motorized Rotations
- Outdoor Applications
- Hoist & Trolley Packages

## Maximize Hoist Lift

This design allows for maximum hoist lift as the beam can be mounted closer to the underside of an overhead obstruction. When combined with bronze bushings and oil impregnated bronze thrust washers, it becomes the perfect solution for easy rotation and precise load positioning.

## Capacities & Spans

- Capacities up to 10 ton
- Standard Span lengths up to 30 feet

## Rotation

205+ degree rotation is standard

## Benefits Vs. Tie Rod Style

- More available headroom to maximize hoist lift

## Options & Accessories

- Tight Wire Kit (Festooning/Tagline)
- Rotation Stops
- Motorized Rotations
- Outdoor Applications
- Hoist & Trolley Packages

## Standards

### Fabrication

All designs meet AISC standards as they pertain to jibs and overhead cranes. All model 313 jib cranes are in accordance with OSHA specification 1910.179. Model 313 jib cranes are built to CMAA specification No. 74. All design and manufacturing is done in accordance to ANSI specification B30.11 as they apply to jib cranes and overhead cranes.

### Material Standards

All steel I beams used by Handling Systems are a minimum of ASTM A-36 designation.

### Deflection Criteria

Standard design is based on  $L(\text{span in inches})/150$ . The value of this formula is theoretical and will be increased during field load tests due to possible variables.

## D.I.Y. Fitting Kits Available



Top Fitting Bracket



Bottom Fitting Bracket

# Mast Type Jib Crane

12+ Ton | 35+ Ft Span | Manual or Motorized

Designed to be floor mounted, with upper support from building truss or bracket. The model 314 provides an economical solution for 360° of rotation with no special foundation requirement thus reducing the cost of installation. Designed for low headroom applications and also available with a drop boom.

## Maneuverability

This design allows for effortless 360° rotation to help with full circumference load positioning of light to heavy work loads.

## Capacities & Spans

- Capacities up to 10 ton
- Standard Span lengths up to 30 feet

## Rotation

360 degree rotation is standard

## Benefits

- Most economical 360 degree rotation jib crane
- No Foundation Requirement
- Perfect solution for overhead crane work cell handling
- Easy rotation even on heavy loads
- Low force exertion on supporting structure
- Maximizes trolley travel
- Full & Drop cantilever available
- Motorized rotation available

## Standards

### Fabrication

All designs meet AISC standards as they pertain to jibs and overhead cranes. All model 314 jib cranes are in accordance with OSHA specification 1910.179. Model 314 jib cranes are built to CMAA specification No. 74. All design and manufacturing is done in accordance to ANSI specification B30.11 as they apply to jib cranes and overhead cranes.

### Material Standards

All steel I beams used by Handling Systems are a minimum of ASTM A-36 designation.

### Deflection Criteria

Standard design is based on  $L(\text{span in inches})/150$ . The value of this formula is theoretical and will be increased during field load tests due to possible variables.



314FC - Full Cantilever

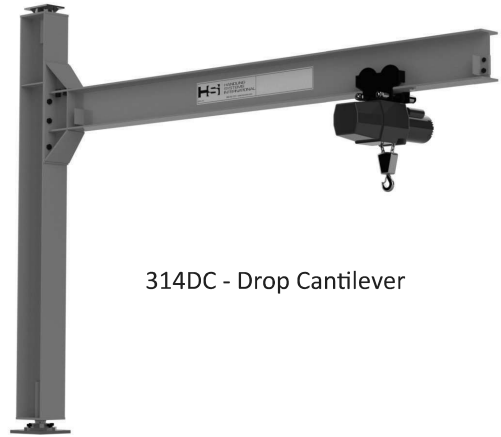

314DC - Drop Cantilever

## Options & Accessories

- Tight Wire Kit (Festooning/Tagline)
- Rotation Stops
- Motorized Rotations
- Outdoor Applications
- Hoist & Trolley Packages

## Special Applications

- Motorized Rotation Available
- Spark and Explosion Proof Options Available
- Stainless Steel & Food grade Options Available

# Light Duty Freestanding Jib Crane

## 1 Ton | 16 Ft Span | 16 Ft HUB

The model 350/350F light duty pillar base mounted jib crane is economical, and is ideal for processes that involve light assembly, welding, or any application where capacity and use are low. Self-supporting 360 degree rotating jib crane. Mounts to floor using manufacturer provided anchor bolts and recommended foundation or existing floor depending on crane specifications.



### Standards

#### Fabrication

All designs meet AISC standards as they pertain to jibs and overhead cranes. All of our model 350/350F jib cranes are in accordance with OSHA specification 1910.179. Model 350/350F jib cranes are built to CMAA specification No. 74. All design and manufacturing is done in accordance to ANSI specification B30.11 as they apply to jib cranes and overhead cranes.

#### Material Standards

All steel I beams used by Handling Systems are a minimum of ASTM A-36 designation. All pipes and tubing are grade ASTM A-500.

#### Deflection Criteria

Standard design is based on  $L(\text{span in inches})/100$ . The value of this formula is theoretical and will be increased during field load tests due to possible variables.

### Maneuverability

This design allows for complete 360° rotation to help with full circumference load positioning for light duty applications.

### Capacities & Spans

- Capacities up to 1 ton
- Standard Span lengths up to 16 feet
- Standard Heights up to 16 feet

### Rotation

360 degree rotation is standard

### Benefits

- Economical pipe over pipe design
- Full plate style gussets for maximum load distribution
- Foundationless Mounting available
- Portable bases available
- Simply componentry makes this jib easy to install

### Options & Accessories

- Tight Wire Kit (Festooning/"Tagline")
- Rotation Stops
- Parking Device
- Templates for Mounting
- Anchoring Systems
- Outdoor Applications
- Food grade Applications
- Spark Proof Applications
- Available in Stainless Steel
- Hoist & Trolley Packages

### Foundationless Mounting Available

- Capacities up to 1 ton
- Standard Span lengths up to 16 feet
- Standard Heights up to 16 feet
- Optional Epoxy Anchoring Systems

# Portable Fork Pocket Jib Crane

## 1 Ton | 16 Ft Span | 16 HUB

The model 350PJ portable fork pocket jib crane is ideal when pouring a foundation is out of the question or when several work areas require the help of a jib crane. Easily move this jib throughout your factory with a standard forklift.

### Maneuverability

This design allows for complete 360° rotation to help with full circumference load positioning for light duty applications. Move around to different areas by means of a standard forklift.

### Capacities & Spans

- Capacities up to 1/2 ton
- Standard Span lengths up to 16 feet
- Standard Heights up to 16 feet

### Rotation

360 degree rotation is standard

### Benefits

- Order base hollow or pre-filled with concrete
- Leveling legs for ease of adjustment
- Boom lock parking device provided for safety and ease of transport
- Economical pipe over pipe design
- Full plate style gussets for maximum load distribution
- Heavy duty precision tapered roller bearings for longevity and ease of rotation

### Options & Accessories

- Tight Wire Kit (Festooning/"Tagline")
- C Track Flat Cable Festooning
- Rotation Stops
- Outdoor Applications
- Hoist & Trolley Packages



### Standards

#### Fabrication

All designs meet AISC standards as they pertain to jibs and overhead cranes. All of our model 350PJ jib cranes are in accordance with OSHA specification 1910.179. Model 350/350F jib cranes are built to CMAA specification No. 74. All design and manufacturing is done in accordance to ANSI specification B30.11 as they apply to jib cranes and overhead cranes.

#### Material Standards

All steel I beams used by Handling Systems are a minimum of ASTM A-36 designation. All pipes and tubing are grade ASTM A-500.

#### Deflection Criteria

Standard design is based on  $L(\text{span in inches})/100$ . The value of this formula is theoretical and will be increased during field load tests due to possible variables.

# Freestanding Articulating Jib Crane

## 1 Ton | 16 Ft Span | 16 Ft HUB

Handling Systems International Freestanding Articulating Jib Cranes can help to position loads in hard to reach places. They are perfect for manipulating around columns, corners, and in and out of narrow passage ways. With true 360 articulation, they have a large coverage area from the boom mast out to the tip of the outer arm. They are a perfect compliment to any hoist, manipulator, balancer and vacuum lifter. Self-supporting 360 degree rotating jib crane. Mounts to floor using Handling Systems anchor bolts and recommended foundation or existing floor depending on crane specifications.



### Standards

#### Fabrication

All designs meet AISC standards as they pertain to jibs and overhead cranes. All of our model 350AJ jib cranes are in accordance with OSHA specification 1910.179. Model 350AJ jib cranes are built to CMAA specification No. 74. All design and manufacturing is done in accordance to ANSI specification B30.11 as they apply to jib cranes and overhead cranes.

#### Material Standards

All steel I beams used by Handling Systems are a minimum of ASTM A-36 designation. All pipes and tubing are grade ASTM A-500.

### Maneuverability

This design allows for complete 360° rotation to help with full circumference load positioning for light duty applications.

### Capacities & Spans

- Capacities up to 1 ton
- Standard Span lengths up to 16 feet
- Standard Heights up to 16 feet

### Rotation

360 degree rotation is standard

### Benefits

- Heavy duty bearing provides full 360 degree rotation
- Full plate style gussets for maximum load distribution
- Easy to install
- Foundationless mounting available
- Portable jib bases available

### Options & Accessories

- Electric & Air Collectors
- Rotation Stops
- Outdoor Application
- Hoist & Below the Hook Packages
- Template and Anchor Bolts
- No Load Parking Device
- Epoxy Anchoring System for foundationless mounting

### Foundationless Mounting Available

- Capacities up to 1 ton
- Standard Span lengths up to 16 feet
- Standard Heights up to 16 feet
- Optional Epoxy Anchoring Systems

# Heavy Duty Freestanding Jib Crane

## 15+ Ton | 35+ Ft Span | Manual or Motorized

The Model 351/351F heavy duty pillar base mounted jib crane is ideal for processes that involve heavy lifting and constant use throughout the day. Fully customizable, this self-supporting 360 degree rotating jib crane mounts to the floor using HSI's anchor bolts and recommended foundation. Foundationless mounting is available in certain capacities, spans and heights.

### Maneuverability

This design allows for complete 360° rotation to help with full circumference load positioning for heavy duty applications.

### Capacities & Spans

- Capacities Exceeding 15 ton
- Standard Span lengths up to 35 feet
- Standard Heights up to 35 feet

### Rotation

360 degree rotation is standard

### Benefits

- Heavy duty assembly with reinforcing side plates
- Full plate style gussets for maximum load distribution
- Foundationless Mounting available
- Heavy duty precision tapered roller bearings for longevity and ease of rotation
- Heavy duty adjustable roller cage with low friction bearings, adjustable tension bolts, and grease fittings
- Anti tip angles prevent head removal from accidental impact and dislodgement

### Options & Accessories

- Tight Wire Kit (Festooning/"Tagline")
- C Track Flat Cable Festooning
- Rotation Stops
- Motorized Rotation
- Templates for Mounting
- Anchoring Systems
- Outdoor Applications
- Food grade Applications

### Standards

#### Fabrication

All designs meet AISC standards as they pertain to jibs and overhead cranes. All model 311 jib cranes are in accordance with OSHA specification 1910.179. Model 351 jib cranes are built to CMAA specification No. 74. All design and manufacturing is done in accordance to ANSI specification B30.11 as they apply to jib cranes and overhead cranes.

#### Material Standards

All steel I beams used by Handling Systems are a minimum of ASTM A-36 designation.

#### Deflection Criteria

Standard design is based on  $L(\text{span in inches})/150$ . The value of this formula is theoretical and will be increased during field load tests due to possible variables.



### Foundationless Mounting Available

- Capacities up to 1 ton
- Standard Span lengths up to 20 feet
- Standard Heights up to 20 feet
- Optional Epoxy Anchoring Systems

### Alternate Mounting Styles

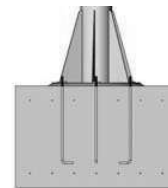

#### Base Plate Mounted (351)

Mast is bolted to foundation (convenient for relocation). Single concrete pour required base plate is welded to mast and reinforced with heavy duty full plate gussets. Custom base and bolt hole patterns available upon request

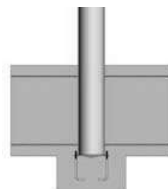

#### Foundation Mounted (352)

Mast permanently secured in foundation. Maximizes floor space (no gussets). Base plate is welded to mast and bolted down to first concrete pour. Second pour secures crane at floor level.

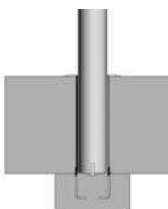

#### Foundation Sleeve Mounted (352S)

Mast secured in foundation with mast sleeve. Maximizes floor space (no gussets). Base plate is welded to mast sleeve and bolted down to first concrete pour. Second pour secures mast sleeve at floor level and crane mast is secured in sleeve with welded sleeve ring.

# Motorized Jib Cranes

## Freestanding | Column/Wall Mounted

The Handling Systems motorized jib crane can be custom built to your exact specifications. Motorized jib cranes can reduce injury and create efficiency during material handling operations. Motorized jibs are used when the material that you are handling is out of reach, too heavy to push manually, or where precise positioning is needed.

Handling Systems motorization packages consist of a chain and sprocket design as standard. Chain and sprocket design offers more consistent rotation than tire drive / tractor drive units. All cranes are fabricated with a VFD control panel, double reduction worm gear reducer in oil bath lubrication, over-sized brake, ½ or ¾ Hp ratings, and a pressure release ventilation system allowing continuous motor usage.



### Features & Benefits

- Chain and Sprocket design
- VFD control is standard
- Control panel, gear box and motor are standard with NEMA 4 enclosures
- Through the door disconnect
- Double reduction worm gear reducer in oil bath lubrication
- Over-sized brake
- ½ or ¾ HP ratings
- Pressure release ventilation system allowing for continuous motor usage

### Options & Accessories

- Galvanized "C" Track flat cable festooning
- Rotational Limit Switch
- Disconnect Switch
- Free traveling pendant station
- Wireless Radio remote
- Weather proofing for outdoor use
- Template and Anchor Bolts

### Crane Availability

Motorization is available for the heavy duty freestanding, wall bracket tie rod, wall bracket cantilever, and mast type style jib cranes. Retrofit motorization kits are also available for these jib crane styles.

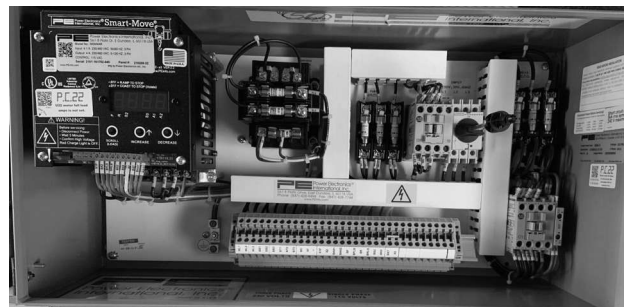

### Standard Panel Features

- NEMA 4 gasketed panel is standard
- Through-the-door disconnect
- Mainline contactor
- System protection
- Motor thermal overload protection
- Fwd/Rev contactors with PE VFD control
- High/Low voltage terminal strip
- 115V control

# Workstation Jib Cranes

## 1/2 Ton | 16 Ft Span | 16 Ft HUB



The model 750/750F freestanding workstation jib crane is economical, and is ideal for processes that involve light assembly, welding, or any application where capacity and use are low. Self-supporting 360 degree rotating jib crane. Mounts to floor using manufacturer provided anchor bolts and recommended foundation or existing floor depending on crane specifications. Enclosed Track provides effortless trolley movement.

### Maneuverability

This design allows for complete 360° rotation to help with full circumference load positioning for light duty applications.

### Capacities & Spans

- Capacities up to 1/2 ton
- Standard Span lengths up to 16 feet
- Standard Heights up to 16 feet

### Rotation

360 degree rotation is standard

### Benefits

- Economical pipe over pipe design
- Full plate style gussets for maximum load distribution
- Foundationless Mounting available
- Portable bases available
- Simply componentry makes this jib easy to install

### Options & Accessories

- Tight Wire Kit (Festooning/"Tagline")
- Rotation Stops
- Parking Device
- Templates for Mounting
- Anchoring Systems
- Outdoor Applications
- Food grade Applications
- Spark Proof Applications
- Available in Stainless Steel
- Hoist & Trolley Packages
- Available in Column and Wall Mounted Variations

### Foundationless Mounting Available

- Capacities up to 1/2 ton
- Standard Span lengths up to 16 feet
- Standard Heights up to 16 feet
- Optional Epoxy Anchoring Systems



### Standards

#### Fabrication

All designs meet AISC standards as they pertain to jibs and overhead cranes. All of our model 750/750F jib cranes are in accordance with OSHA specification 1910.179. Model 750/750F jib cranes are built to CMAA specification No. 74. All design and manufacturing is done in accordance to ANSI specification B30.11 as they apply to jib cranes and overhead cranes.

#### Material Standards

All steel I beams used by Handling Systems are a minimum of ASTM A-36 designation. All pipes and tubing are grade ASTM A-500.

#### Deflection Criteria

Standard design is based on  $L(\text{span in inches})/100$ . The value of this formula is theoretical and will be increased during field load tests due to possible variables.

# Foundationless Jib Cranes

1 Ton | 20 Ft Span | 20 Ft HUB

MODEL 350F/750F - LIGHT DUTY

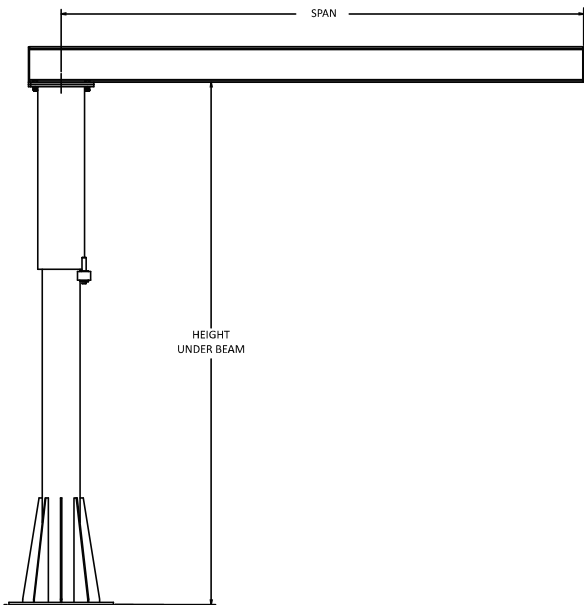

MODEL 351F - HEAVY DUTY

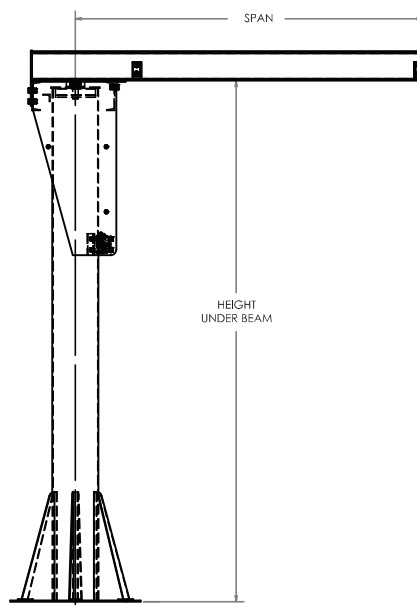

MAX CAPACITY	MAX SPAN	MAX HUB
1/2 TON	16 FT	16 FT
1 TON	10 FT	12 FT

MAX CAPACITY	MAX SPAN	MAX HUB
1/2 TON	20 FT	16 FT
1 TON	16 FT	16 FT

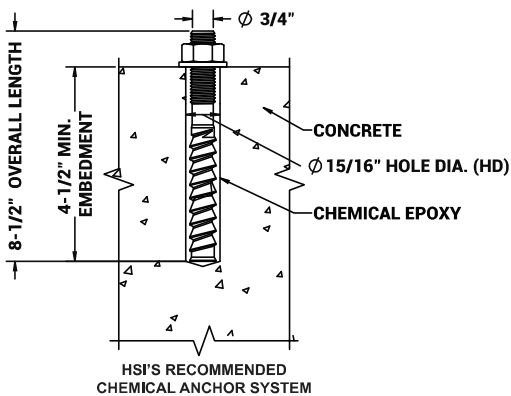

IT IS RECOMMENDED THAT FOUNDATIONLESS JIB CRANES BE MOUNTED ON REINFORCED CONCRETE WITH A MINIMUM DEPTH OF 6" AVOIDING ANY GAPS, CRACKS, OR EXPANSION JOINTS (WITHIN A GIVEN AREA, SIZE OF AREA TO BE DETERMINED BY QUALIFIED ENGINEER). ANCHOR BOLTS MUST HAVE A 4 1/2" MINIMUM EMBEDMENT.

IT IS NOT HANDLING SYSTEMS INTERNATIONAL INC'S RESPONSIBILITY TO VERIFY THE SUITABILITY OF A FLOOR OR STRUCTURE TO WHICH OUR PRODUCT IS MOUNTED. PRIOR TO MOUNTING, IT IS REQUIRED THAT THE CUSTOMER/END USER SEEK ADVICE FROM A QUALIFIED ENGINEER.

# Fixed Height Steel Gantry Crane

## 15+ Ton | 40+ Ft Span | Manual or Motorized

Designed for everyday use, gantry cranes are recommended for production, installation, and maintenance service where portability is required. Depending on the capacity, the gantry is equipped with phenolic, poly coated, or forged steel heavy duty swivel casters. All caster types feature roller bearings for ease of movement and grease fittings are included for ease of maintenance. 'V' Groove and flanged wheels are also available upon request.

### Maneuverability

This design allows for complete portability with swivel casters to move around to various work areas.

### Capacities & Spans

- Capacities up to 15+ ton
- Standard Span lengths up to 40+ feet
- Standard Heights up to 25+ feet

### Benefits

- Economical solution when portability is required
- No Foundation Requirement
- Motorization Available

### Options & Accessories

- Tight Wire Kit (Festooning/"Tagline")
- C Track Flat Cable Festooning
- Caster Swivel Locks
- Caster Wheel Locks (brakes)
- Rigid or 'V' Groove Casters
- Outdoor Applications
- Hoist & Trolley Packages
- Motorization

### Standards

#### Fabrication

All designs meet AISC standards as they pertain to gantry and overhead cranes. All model 511 gantry cranes are in accordance with OSHA specification 1910.179. Model 511 gantry cranes are built to CMAA specification No. 74. All design and manufacturing is done in accordance to ANSI specification B30.11 as they apply to gantry cranes and overhead cranes.

### Material Standards

All steel beams and shapes used by Handling Systems International are a minimum of ASTM A-36 designation. All steel pipes are ASTM A-53 Grade B. All steel tubing are ASTM A-500 Grade B. All aluminum used meets ASTM B308 for 6061-T6 aluminum.

### Deflection Criteria

Standard steel gantry crane design is based on  $L(\text{span in inches})/600$ . The value of this formula is theoretical and will be increased during field load tests due to possible variables.



### Casters for Any Application



Phenolic



Poly Coated



V Groove



Steel Wheel



Pneumatic



Dual Wheel

# Adj. Height Steel Gantry Crane

## 15+ Ton | 40+ Ft Span | Manual or Motorized

Designed for everyday use, gantry cranes are recommended for production, installation, and maintenance service where portability is required. Depending on the capacity, the gantry is equipped with phenolic, poly coated, or forged steel heavy duty swivel casters. All caster types feature roller bearings for ease of movement. Grease fittings are included for ease of maintenance. 'V' Groove and flanged wheels are also available upon request.



Ratchet Lever Height Adjustment

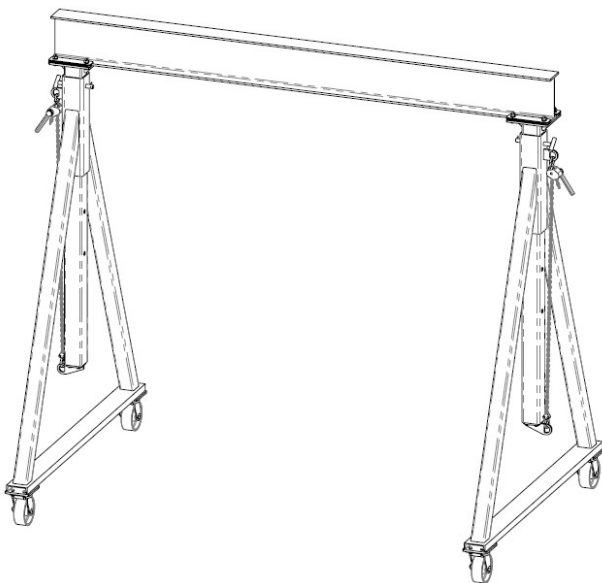

### Maneuverability

This design allows for complete portability with swivel casters to move around to various work areas. Adjustable height to get through doorways or under machines/overhead obstructions as well as the option for higher lift applications.

### Capacities & Spans

- Capacities up to 15+ ton
- Standard Span lengths up to 40+ feet
- Standard Heights up to 25+ feet

### Benefits

- Adjustable height and span
- Economical solution when portability is required
- No Foundation Requirement
- Motorization Available

### Options & Accessories

- Tight Wire Kit (Festooning/"Tagline")
- C Track Flat Cable Festooning
- Caster Swivel Locks
- Caster Wheel Locks (brakes)
- Rigid or 'V' Groove Casters
- Outdoor Applications
- Hoist & Trolley Packages
- Motorization

### Standards

#### Fabrication

All designs meet AISC standards as they pertain to jibs and overhead cranes. All model 512 gantry cranes are in accordance with OSHA specification 1910.179. Model 512 gantry cranes are built to CMAA specification No. 74. All design and manufacturing is done in accordance to ANSI specification B30.11 as they apply to jib cranes and overhead cranes.

#### Material Standards

All steel beams and shapes used by Handling Systems International are a minimum of ASTM A-36 designation. All steel pipes are ASTM A-53 Grade B. All steel tubing are ASTM A-500 Grade B. All aluminum used meets ASTM B308 for 6061-T6 aluminum.

#### Deflection Criteria

Standard steel gantry crane design is based on  $L(\text{span in inches})/600$ . The value of this formula is theoretical and will be increased during field load tests due to possible variables.

# Aluminum Gantry Crane

## 3 Ton | 15 Ft Span | Fixed or Adjustable Height

Designed for everyday use, gantry cranes are recommended for production, installation, and maintenance service where portability is required. Depending on the capacity, the gantry is equipped with phenolic, poly coated, or forged steel heavy duty swivel casters. All caster types feature roller bearings for ease of movement and grease fittings are included for ease of maintenance. 'V' Groove and flanged wheels are also available upon request.

### Maneuverability

This design allows for complete portability with swivel casters to move around to various work areas. Adjustable height to get through doorways or under machines, overhead obstructions as well as the option for higher lift applications. Aluminum construction makes for ease of use and installation.

### Capacities & Spans

- Capacities up to 3 ton
- Standard Span lengths up to 20 feet
- Standard Heights up to 12 feet

### Benefits

- Light weight and easy to assemble/disassemble
- Economical solution when portability is required
- No Foundation Requirement

### Options & Accessories

- Tight Wire Kit (Festooning/"Tagline")
- C Track Flat Cable Festooning
- Caster Swivel Locks
- Caster Wheel Locks (brakes)
- Rigid or 'V' Groove Casters
- Outdoor Applications
- Hoist & Trolley Packages

### Standards

#### Fabrication

All designs meet AISC standards as they pertain to jibs and overhead cranes. All model 582 gantry cranes are in accordance with OSHA specification 1910.179. Model 582 gantry cranes are built to CMAA specification No. 74. All design and manufacturing is done in accordance to ANSI specification B30.11 as they apply to overhead cranes.

#### Material Standards

All steel aluminum used by Handling Systems meets ASTM International specification ASTM B308 for 6061-T6 Aluminum.

#### Deflection Criteria

Standard design is based on  $L(\text{span in inches})/450$ . The value of this formula is theoretical and will be increased during field load tests due to possible variables.



### Casters for Any Application



Phenolic



Poly Coated



V Groove



Steel Wheel



Pneumatic



Dual Wheel

# Motorized Gantry Cranes

15+ Ton | 35+ Ft Span | Dual or Single Leg

Safe and efficient, our motorized gantry cranes are perfect to service a large area at a high capacity. Single and double leg gantry cranes are available in several capacities and sizes to meet your needs without breaking the bank.



## Capacities & Spans

- Capacities up to 10+ ton
- Standard Span lengths up to 30+ feet
- Standard Heights up to 30+ feet
- Custom heights and spans available

## Benefits

- Customizable Heights and Spans
- Perfect solution when building is not suited to support jib/bridge cranes
- Economical motorized solution when high capacity and greater area coverage is required
- Great for a rented space; can be relocated in the future
- No Foundation Requirement
- Track required on ONE side only
- VFD Control comes standard
- Galvanized Flat Cable Festooning comes standard

## Options & Accessories

- Tight Wire Kit (Festooning/"Tagline")
- C Track Flat Cable Festooning
- Caster Swivel Locks
- Caster Wheel Locks (brakes)
- Rigid or 'V' Groove Casters
- Outdoor Applications
- Hoist & Trolley Packages
- Motorization

## Standards

### Fabrication

All designs meet AISC standards as they pertain to jibs and overhead cranes. All model 514 gantry cranes are in accordance with OSHA specification 1910.179. Model 514 gantry cranes are built to CMAA specification No. 74. All design and manufacturing is done in accordance to ANSI specification B30.11 as they apply to overhead cranes.

### Material Standards

All steel I beams used by Handling Systems are a minimum of ASTM A-36 designation.

### Deflection Criteria

Standard design is based on  $L(\text{span in inches})/600$ . The value of this formula is theoretical and will be increased during field load tests due to possible variables.



# Bridge Cranes & Runways

10+ Ton | 55+ Ft Span | Manual or Motorized

- Pre-engineered for quick delivery
- Bolt-together construction
- Easy installation
- Ships complete with electrification, all hardware and anchor bolts
- Modular design for easy relocation
- All runway systems are designed to AISC specifications

## Underhung Systems



Freestanding Runway System



Ceiling-Mounted Runway System

## Top Running Systems



Free Standing Top-Running



Semi-Free Standing Top-Running



High Capacity Free Standing (Olympus)

# Monorails

10+ Ton | 55+ Ft Span | 20+ HUB



Handling Systems offers a wide variety of straight and curved ceiling and floor mounted monorail systems. Ceiling mounted systems are available with drop or flush mount hangers. Floor mounted systems are available in both 'A' frame and 'H' frame supports. With the expertise to engineer and design, Handling Systems is capable of manufacturing most any custom built free standing monorail system to accommodate a variety of applications.

Handling Systems offers both 'A' frame style monorail supports (floor mounted gantry style) or 'H' frame straddle leg supports. 'H' frame support structure allows for support column placement free of machinery and forklift traffic.

A monorail system consists of a single straight or curved I beam supported at each end (middle supports may be necessary depending on size) with a trolley and hoist to travel back and forth for material handling. Monorail systems are used to aid in material handling where x,y,z movement like that in a bridge crane is not needed. Most commonly used over a row of machines, in hallways or passages, through paint booths, or to assist in truck loading. Monorail systems are available with festooning packages to keep the air hose or power cord out of the way of the load and user.



# Nikorail Workstation Cranes

## Enclosed Track Crane Systems by H.S.I.

NikoRail by Handling Systems International, is the exclusive US provider of enclosed track for Helm Hellas SA, leading European manufacturers of light cranes, power feed systems, overhead conveyors, sliding door track and fall arrest track systems.

The Niko group was established in 1972 and has 7 locations and a comprehensive distributor network, giving Niko presence across Europe, North America, Asia, Australia and North Africa.

The experienced engineers at NikoRail take pride in offering quality products, rapid lead times and a high level of customer service to provide solutions for a wide range of material handling situations

These systems are fabricated by Handling Systems International, in McCook, IL USA.



NIKORAIL Light Crane System provides an ergonomic and cost effective solution to conventional overhead crane systems, particularly when there is a height and space restriction. Versatile and reliable overhead handling can be achieved for a variety of applications using the NIKORAIL modular design. The robust design of our components and the high standards of manufacturing guarantees long life with little or no maintenance requirements. Our product range consists of sliding door fittings, overhead conveyor systems, festoon systems, fall arrest systems and light cranes.

#### Features & Benefits

- Loads up to 4400lbs
- Bridge lengths up to approximately 33 feet
- Modular design enables extension, modification and relocation
- Cost effective
- Easy to install using a variety of supporting brackets
- Large range of mounting options
- Latching capability enables interconnection with existing or new
- Conveyor or monorail systems
- Telescopic cantilever crane bridges and monorails
- Manual or electric travel
- Floor or ceiling mounted cranes
- Painted or electrolytic plated finish
- Cranes available in stainless steel



# Nikoline Fall Protection

## Fall Arrest Protection Systems by H.S.I.

NikoLine Fall Protection Systems provide a very safe and practical safety system for people working at height. According to OSHA a fall protection system is designed to arrest or prevent falls from a height. OSHA standards state that any time a worker is at a height of four feet or more, the worker is at risk and needs to be protected. Fall protection must be provided at four feet in general industry, five feet in maritime and six feet in construction. However, regardless of the fall distance, fall protection must be provided when working over dangerous equipment and machinery. The US Department of Labor (DOL) lists falls as one of the leading causes of traumatic occupational death, accounting for eight percent of all occupational fatalities from trauma.

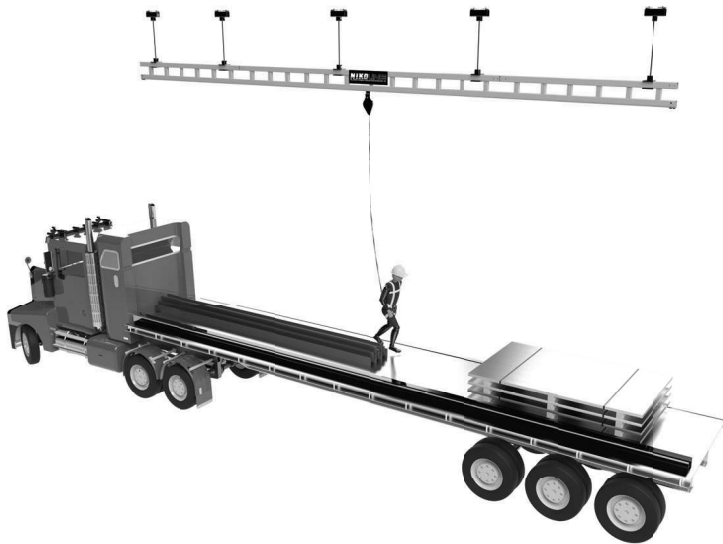

### Types of System

- Single rail fall arrest track system
- Double rail fall arrest track system
- Bridge crane fall arrest track system

### Applications

- Aircraft service and maintenance
- Safety track for high ropes courses
- Coach service and maintenance
- Sky glide track for soft play areas
- Train service and maintenance

### Benefits

#### Advantages of NikoLine Fall Protection Track vs Taut Wire Fall Protection System

- There is less distance to fall with NikoLine fall protection track and therefore less impact on the body
- No bouncing effect, which can cause injury on secondary falls
- Multiple person systems are safer with NikoTrack fall protection track. One person falling on a taut wire fall protection systems can cause other users to fall
- Following a fall the Niko fall protection track can be re-used immediately after passing a visual inspection. Taut wire systems need to be completely replaced
- The tapered edge design of the NikoLine fall protection track achieves very free running movement and eliminates snag effect
- Its modular design means that the NikoTrack fall protection track systems can be easily moved, added to and changed after installation
- NikoLine fall protection track offers solutions that enable operators to pass each other without detaching themselves from the system
- No length-limit of distance of NikoTrack fall protection track systems
- NikoLine Fall Protection Systems offer very little interference with workers tasks or activities and will easily/naturally move with the worker
- Because of NikoLines self aligning trolleys, the safety tether will remain directly above the user, therefore eliminating the possibility of a swing fall
- Because of the enclosed track design, NikoLine systems are not susceptible to snow, ice, or debris, which allows for year round use of the system

# Design Standards

## Design Standards

All Handling Systems International Jib Cranes are structurally designed in accordance with the AISC Steel Construction Manual.

All Handling Systems International Cranes have a design factor of 15% of the allowable capacity for hoist weight and 25% of the allowable capacity for impact.

All designs meet AISC standards as they pertain to jibs and overhead cranes. All of our cranes are in accordance with OSHA specification 1910.179. All design and manufacturing is done in accordance to ANSI specification B30.11 as they apply to jib cranes and overhead cranes. All jib and gantry cranes are built to CMAA specification No. 74. All workstation bridge cranes are built to MMA MH27.2.

## Fabrication Standards

All welding of Handling Systems International cranes adheres to the American Welding Society's (AWS) standards: D1.1 for steel and D1.2 for aluminum. All welders are AWS certified.

## Material Standards

All steel beams and shapes used by Handling Systems International are a minimum of ASTM A-36 designation. All steel pipes are ASTM A-53 Grade B. All steel tubing are ASTM A-500 Grade B. All aluminum used meets ASTM B308 for 6061-T6 aluminum.

## Painting Procedure

All finished cranes are wire wheel cleaned and wiped down with a solvent solution paint prep to remove any standing rust, oil, or dirt that may impede in paint adhesion. Indoor and outdoor paint finishes are applied with an air-assisted wet paint sprayer. Standard indoor paint consists of a one to two coat, 2 mil +/- application with a DTM water reducible yellow baked on enamel. Standard outdoor paint finish consists of a one coat DTM primer with two coats of water reducible safety yellow baked on acrylic enamel. Solvent based, epoxy paint finishes and galvanization are all available upon request.

## Deflection

HSI manufactures cranes to a specific deflection value, however, the value of this formula is theoretical and will be increased during field load tests due to variables such as: installation, foundation rigidity, or the standard variation in thickness tolerances for the piping, tubing, steel plate and sheet metal. Some variation above (or below) deflections defined by the manufacturer is considered normal. When measuring deflection for safety standards, the deflection is measured at 100 percent capacity  $L$  (span in inches)/150 for freestanding (350),  $L$  (span in inches)/150 for wall cantilever (313), free standing (351), and mast type (314), and  $L/450$  for wall bracket (311) cranes), rather than the 125 percent load test. According to ANSI Standards (ANSI/ASME B30.2), "Standard deflection must be measure with a load of 100 percent of the rated capacity". During load testing at 125% deflection values will thus be greater than published deflection. Using this formula, ' $L$ ' (meaning Length or span) measured in inches / 100 will result in a theoretically calculated deflection. Load tests at 125% of rated capacity plus variables listed above can result in up to twice the theoretical deflection value.



# 11 Year Warranty

HSI's 11 year warranty is the best in the industry.

## What Products Are Covered?

- Manual Rotation Jib Cranes
- Manual Steel Gantry Cranes
- Defects in material and workmanship

## The Fine Print:

Handling Systems International, Inc. (known as H.S.I.) warrants manual push/pull Jib and Gantry Crane products it manufactures against defects in material or workmanship for a period of eleven years from date of receipt by purchaser or customer. This warranty does not cover failure or defect in paint or material finish. This warranty does not cover failure or defect caused by operation in excess of recommended rated capacities, misuses, negligence or accident, and alteration or repair of any kind not authorized by H.S.I. H.S.I. systems shall not be modified after manufacture without written authorization of H.S.I. Any field modifications made without written authorization of H.S.I. shall void all H.S.I.'s warranty obligation. H.S.I. agrees to furnish the same or substantially similar replacement part (new or repaired) free of charge, providing the buyer gives immediate written notice of alleged defects, and if requested by H.S.I., returns the defective parts to the factory, for H.S.I.'s inspection and examination. Purchaser or end user shall be solely responsible for all freight and transportation costs incurred in connection with any warranty work provided by H.S.I. hereunder. H.S.I. will not be liable for any loss, injury or damage to persons or property, nor for damages of any kind resulting from failure or defective operation of any materials or equipment furnished hereunder. H.S.I. shall not be liable under any circumstances for any incidental, special and/or consequential damages whatsoever, whether or not foreseeable, including but not limited to damages for lost profits and all such incidental, special and/or consequential damages are hereby also specifically disclaimed. This warranty applies only to H.S.I. equipment or materials which, after our inspection, are determined to be defective either in material supplied or workmanship performed by H.S.I. Where equipment is furnished by H.S.I. but not of its manufacture, H.S.I.'s liability is limited to such adjustment as the actual manufacturer makes to H.S.I. H.S.I. will not be liable for the cost of repairs, alterations, or replacements or any expense connected therewith made or incurred by the purchaser or his agents or employees, except upon written authority from H.S.I. This warranty is personal to purchaser only and applies only to equipment which purchaser has properly operated and maintained in accordance with H.S.I.'s written instructions. H.S.I. assumes no liability for any consequential damages suffered through the use of loss of use of its equipment. This constitutes H.S.I.'s sole warranty with respect to the equipment and material manufactured by itself. H.S.I. makes no other warranty of any kind whatsoever, expressed or implied, and all implied warranties of merchantability and fitness for a particular purpose which exceed the aforementioned obligation are hereby disclaimed by H.S.I.

